



Planta baixa
ESC: 1 : 50



Vista geral sudoeste
ESC:



Vista geral sudeste
ESC:

SOLEDADE
Lazer e Esportes

PROJETO
REFORMA PRACINHA FARROUPILHA

LOCAL
Esquina Rua Rio Branco e Rua 7 de Setembro

RESPONSÁVEL TÉCNICO
Giovani Bettio

PROPRIETÁRIO
P. M. Soledade

COLABORAÇÃO
Projetista

ASSUNTO
Anteprojeto

FRANCHA
A101

VERSÃO

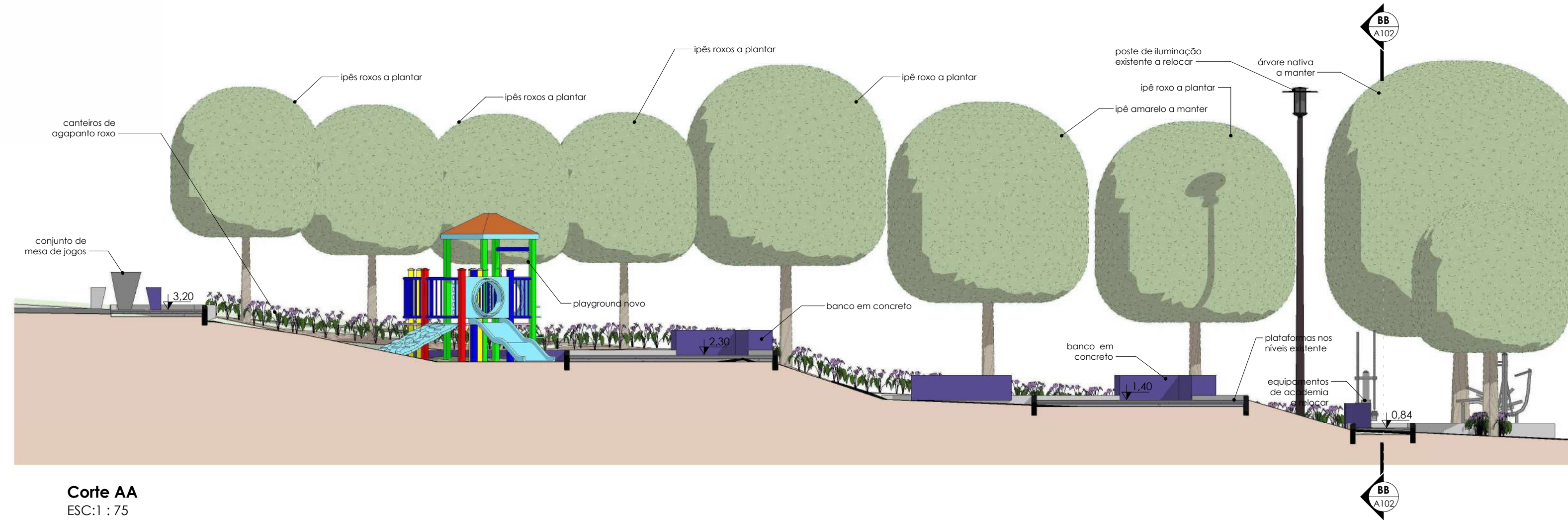

Corte AA
ESC: 1 : 75

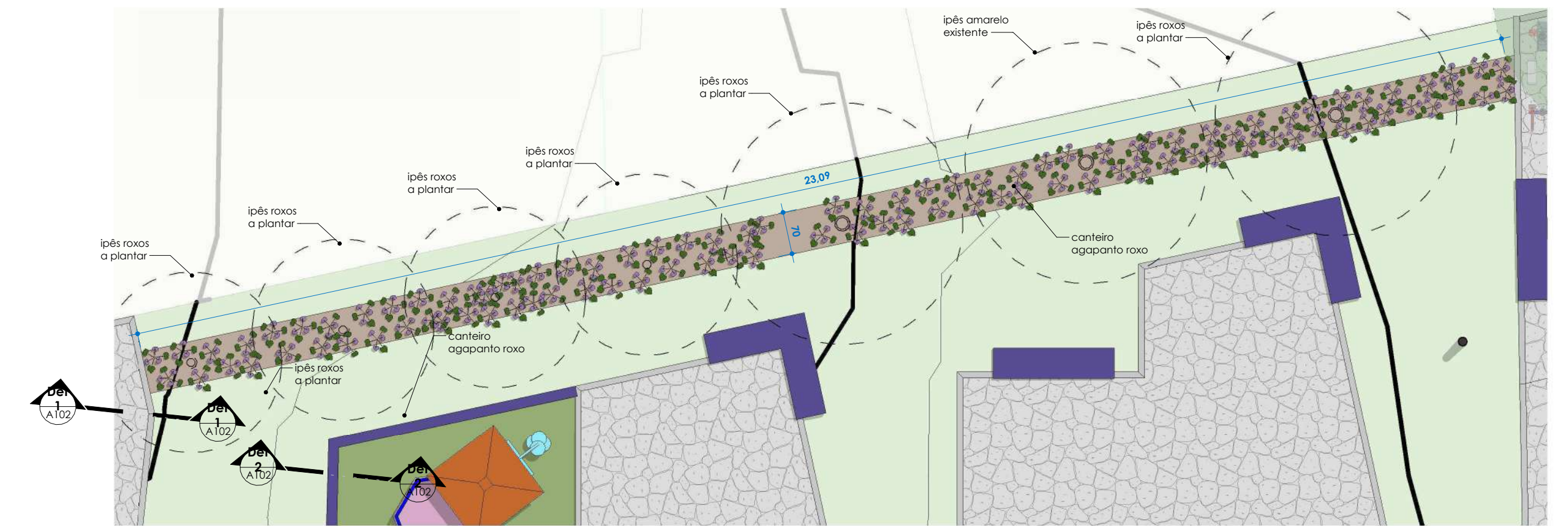

Detalhe canteiros agapanto roxo NORTE
ESC: 1 : 75



Corte BB
ESC: 1 : 75



Situação/Localização
ESC: 1 : 200

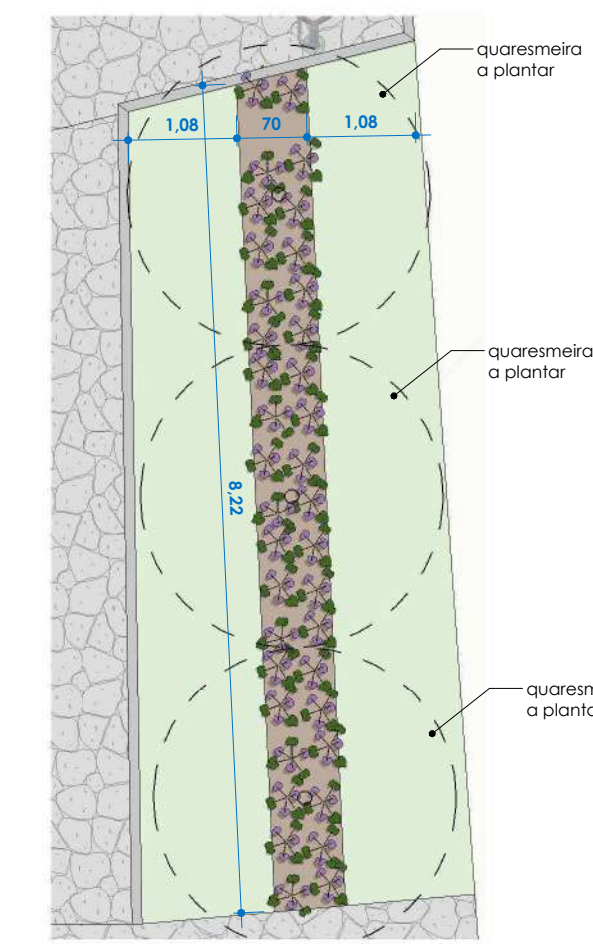

Detalhe canteiros agapanto roxo LESTE
ESC: 1 : 75



Vista mesas de jogos
ESC:

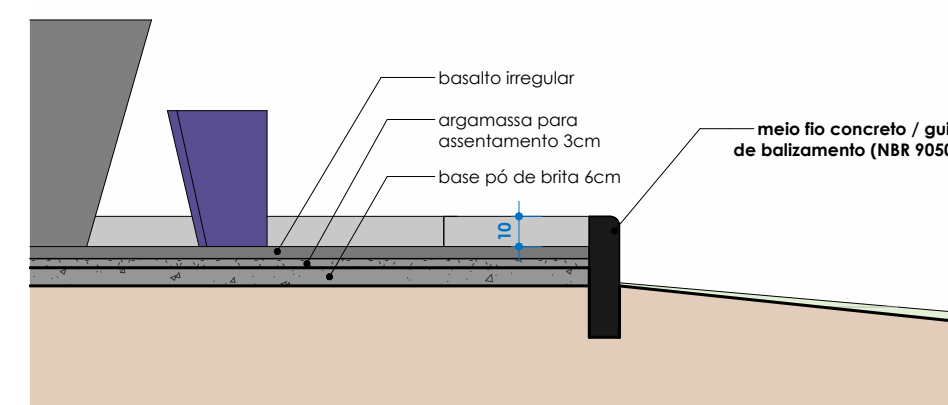

Det 1 / Acessibilidade
ESC: 1 : 25

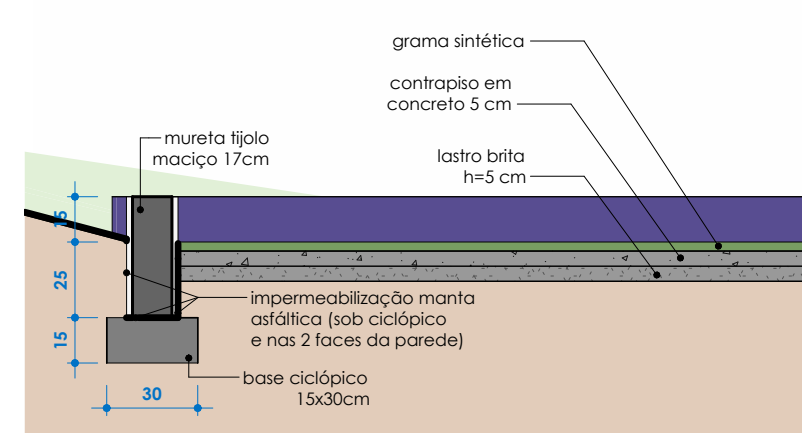

Det 2 / Piso grama sintética
ESC: 1 : 25

SOLEDADE CONSTRUTORA

REFORMA PRACINHA FARROUPILHA

PROJETO

LOCAL
Esquina Rua Rio Branco e Rua 7 de Setembro

RESPONSÁVEL TÉCNICO
Giovani Bettio

PROPRIETÁRIO
P. M. Soledade

COLABORAÇÃO
Projetista

ASSUNTO
Detalhamento

FRANCHA
A102

VERSÃO

© 2023 Soledade Engenharia de Projetos Ltda. Rua Farroupilha, 100 - Fátima - Porto Alegre - RS - Brasil

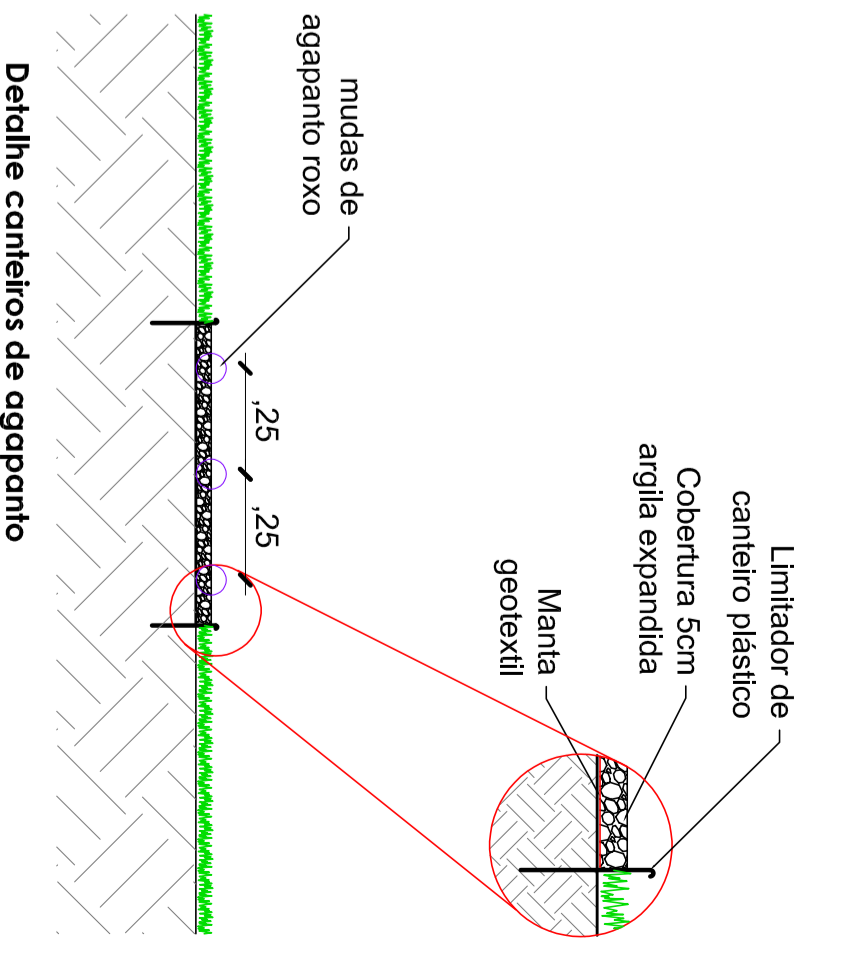
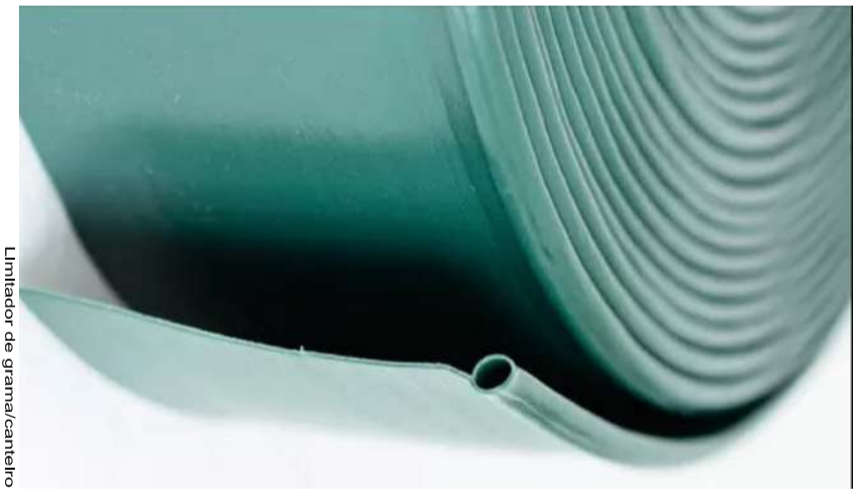
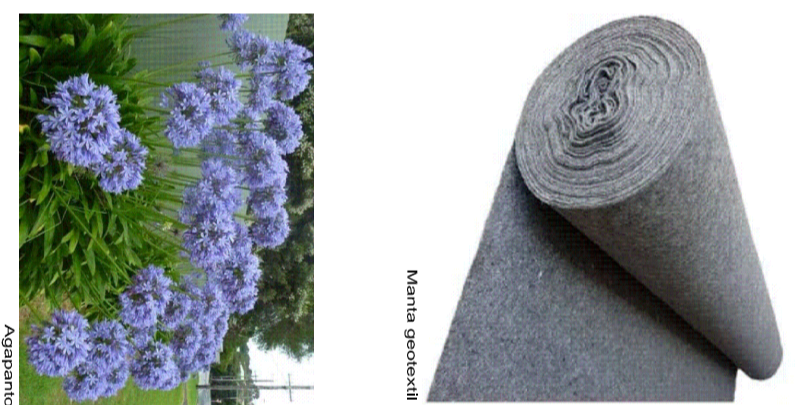
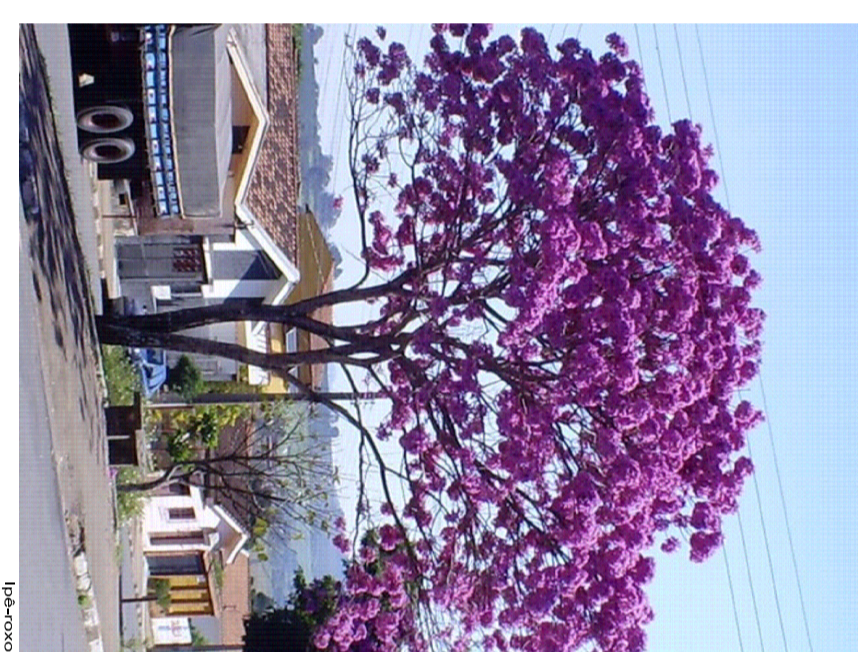
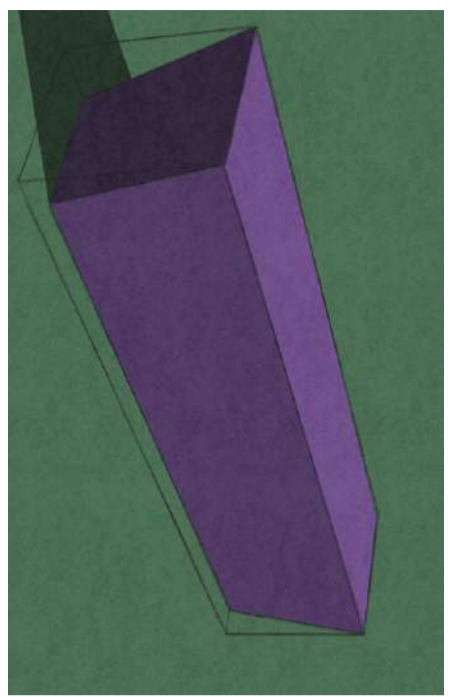
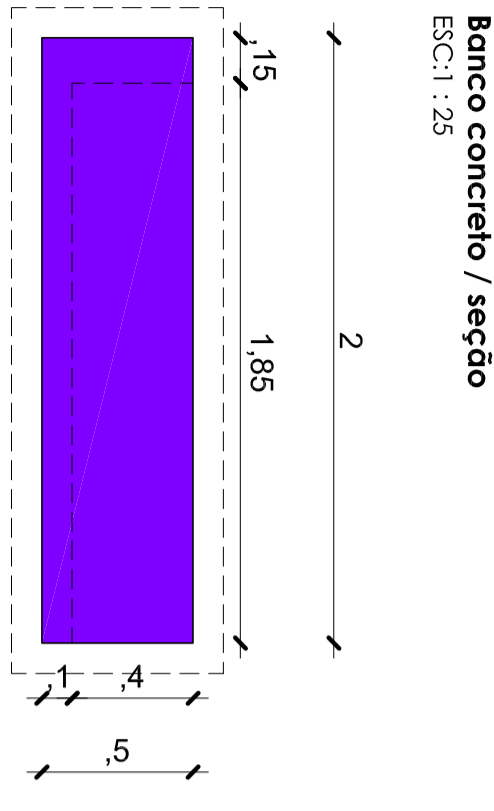
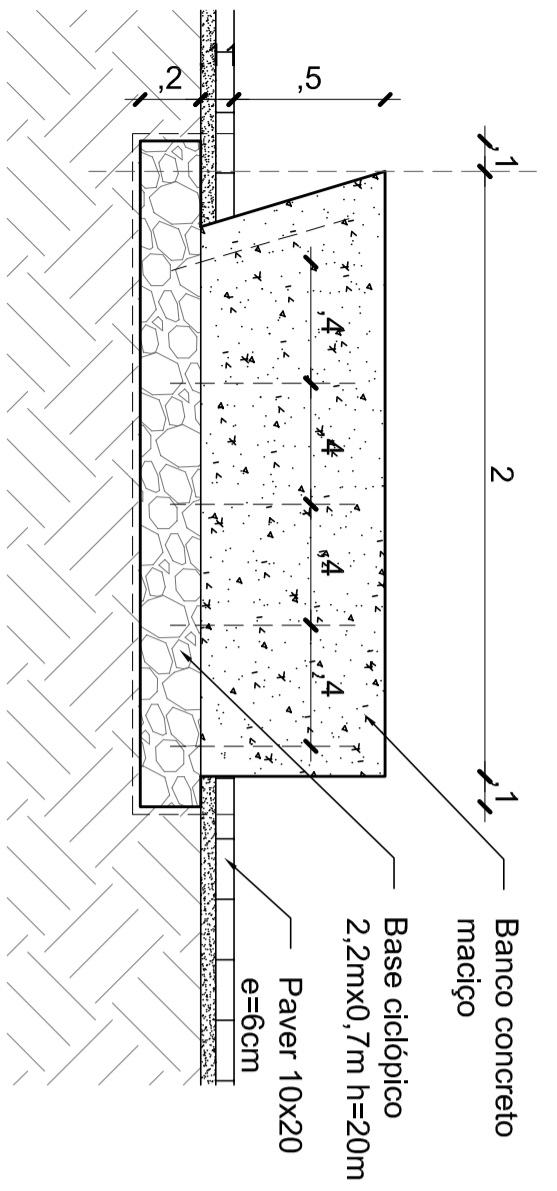
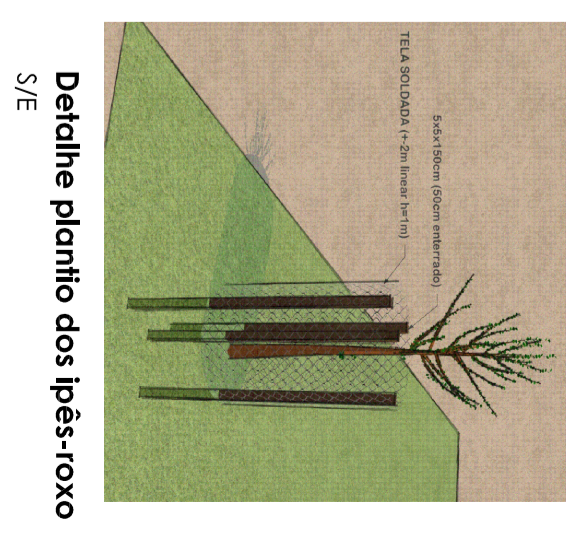
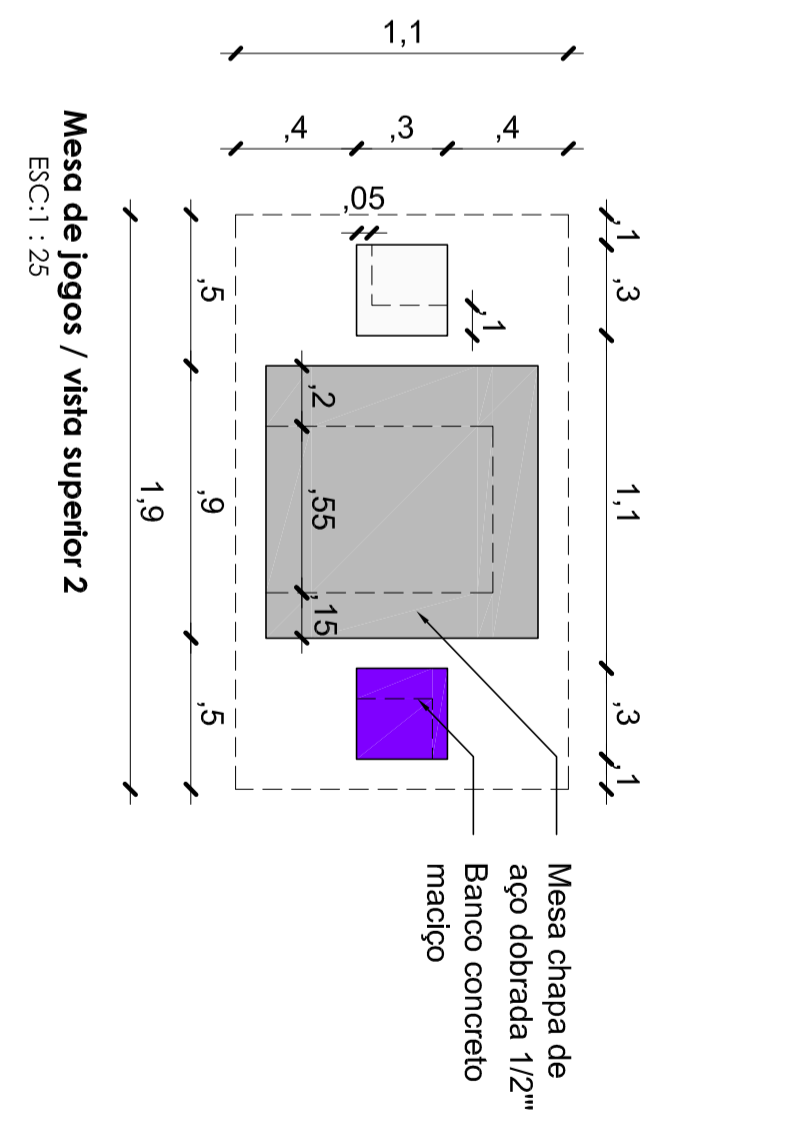
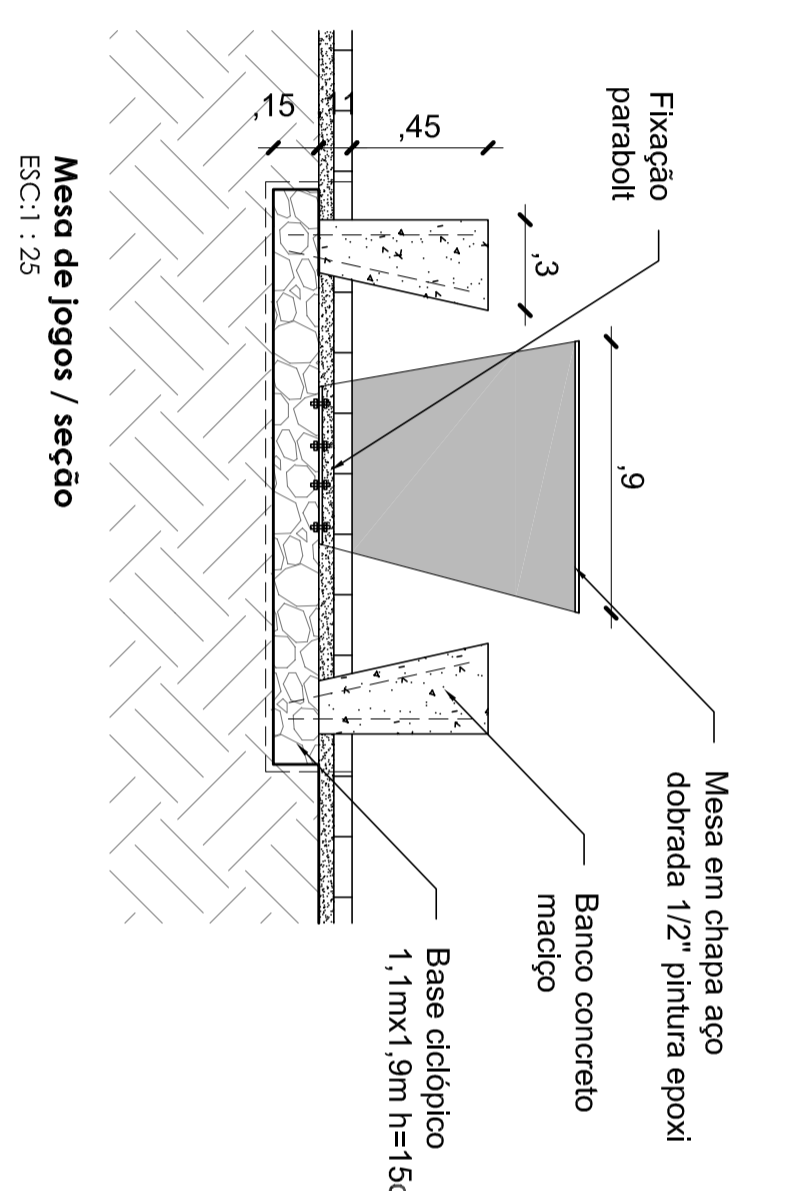
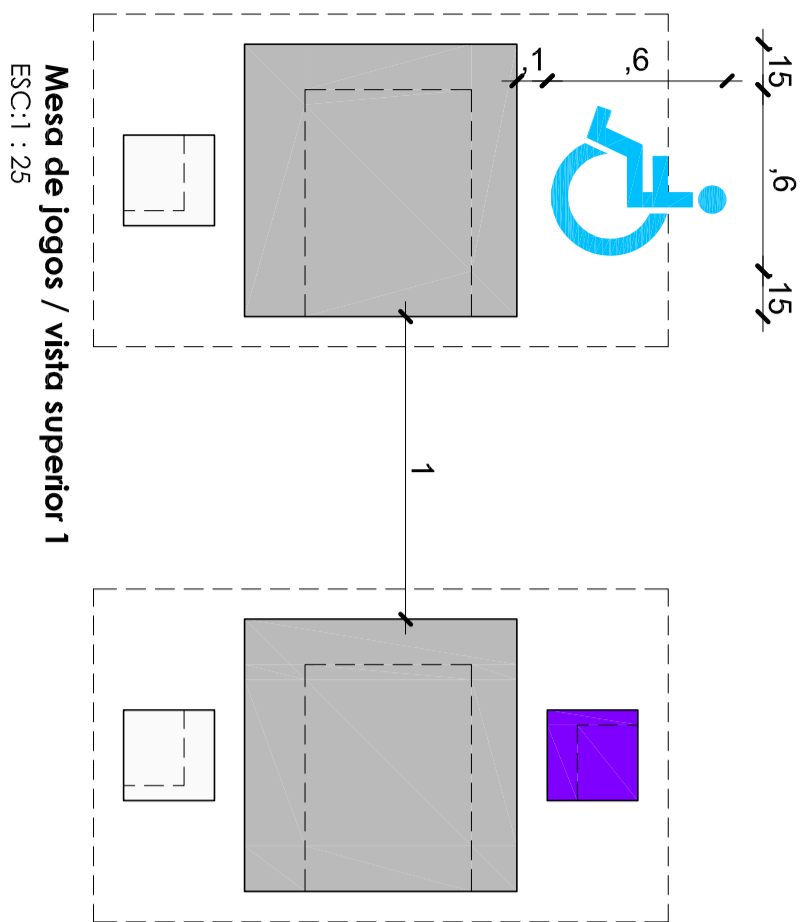

PROJETO
REFORMA PRACINHA FARROUPILHA

LOCAL
 Esquina Rua Rio Branco e Rua 7 de Setembro

RESPONSÁVEL TÉCNICO
 Giovanni Bethio

PROPRIETÁRIO
 P. M. Soledade

COLABORAÇÃO
 Projetista
 ASSUNO

RESPONSÁVEL TÉCNICO

PROPRIETÁRIO

FRANCHA
 A103

VERSÃO





VERIFICAÇÃO DAS ASSINATURAS



Código para verificação: B7CA-2640-9B2E-03F5

Este documento foi assinado digitalmente pelos seguintes signatários nas datas indicadas:

- ✓ MARA GORETE MUNIZ DO AMARAL (CPF 367.XXX.XXX-68) em 08/04/2024 17:01:08 (GMT-03:00)
Papel: Assinante
Emitido por: Sub-Autoridade Certificadora 1Doc (Assinatura 1Doc)

- ✓ CLAIR CAMARGO DE OLIVEIRA (CPF 851.XXX.XXX-78) em 08/04/2024 18:50:06 (GMT-03:00)
Papel: Assinante
Emitido por: Sub-Autoridade Certificadora 1Doc (Assinatura 1Doc)

Para verificar a validade das assinaturas, acesse a Central de Verificação por meio do link:

<https://soledade.1doc.com.br/verificacao/B7CA-2640-9B2E-03F5>